

PENOUEST



Aléuseuse portative SUPERCOMBINATA ELSA SC2-600

Alésage de $\varnothing 62$ mm à $\varnothing 600$ mm avec l'équipement standard

Avec les options :

Alésage de $\varnothing 25$ mm à 600 mm

Rechargement de $\varnothing 35$ mm à 600 mm

Poids unité principale : 42 kg

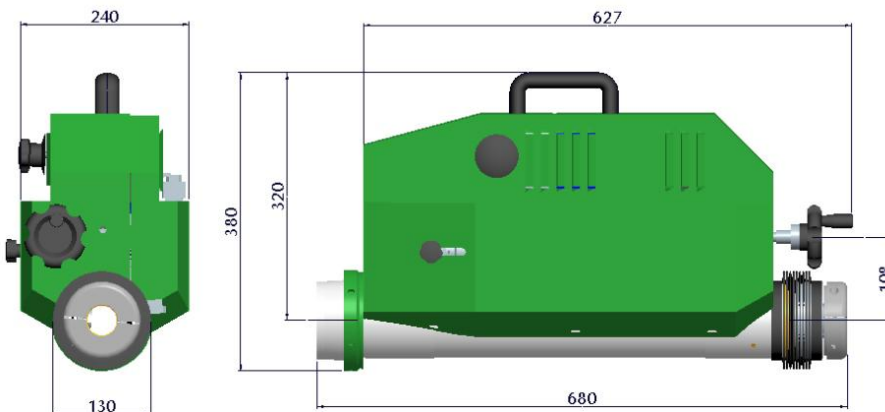

Moteur pour alésage	
Puissance nominale 1800 W	Vitesses maxi de la barre 1 ^{ère}) 65 rpm 2 ^{ème}) 110 rpm 3 ^{ème}) 230 rpm 4 ^{ème}) 360 rpm

Moteur d'avance - DC			
Puissance nominale 90 W	Vitesse maximale 11 rpm	Système de l'avance électromécanique	Avancement Manuel/automatique

Pupitre de commande 220 V (50/60 HZ)	
Interrupteur principal de mise sous tension Interrupteur d'arrêt d'urgence Inverseur rotation d'alésage	Potentiomètre réglage vitesse de rotation Inverseur de déplacement barre ou torche Potentiomètre de vitesse de déplacement



01-17-11

Kenyah nord, rue de l'avenir – 56400 Plougoumen France

Tél : (33) 02 97 24 16 59 – E-mail : accueil@penouest.com – Site: www.penouest.com

SA au capital de 300 000 Euros – RCS Lorient B 391 833 019 – Siret 391 833 019 00014 – APE 4669 B – N° identification TVA FR 10391833019

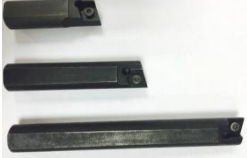
Equipement standard de l'aléreuse **SUPERCOMBINATA SC2-600** Capacité d'alésage de \varnothing 62 mm à 600 mm

 <p>1 barre d'alésage \varnothing 60 x 2200</p>	 <p>1 allonge barre d'alésage 520 mm</p>	 <p>Centrale de commande électronique + câbles</p>	 <p>1 porte-outil \varnothing 12 x 100 DR 1 porte-outil \varnothing 12 x 60 GA 1 porte-outil spécial \varnothing 12 x 60 GA</p>
 <p>1 boîte de 10 plaquettes</p>	 <p>1 bague porte outil pour travaux de \varnothing 120 à 250 mm</p>	 <p>1 bague porte outil de \varnothing 250 à 600 mm</p>	 <p>1 kit de centrage trous débouchants</p>
 <p>1 mécanisme de centrage de \varnothing 250 à 600 mm</p>	 <p>kit de centrage trous borgnes</p>	 <p>4 brides pour support de \varnothing 250 à 600 mm</p>	 <p>18 étriers support brides</p>
 <p>2 paliers principaux</p>	 <p>2 paliers intermédiaires</p>	 <p>1 jeu de clés de service</p>	 <p>1 jauge intérieure (microspand)</p>
 <p>1 bague réglage porte-outil</p>	 <p>1 comparateur + 1 support comparateur</p>	 <p>18 boulons hex. M14X80 mm 18 vis six-pans m. M14X50mm 18 écrous hex. M14</p>	 <p>1 bâti d'aléreuse</p>
OPTION RECHARGEMENT			
 <p>1 torche de rechargement</p>	 <p>3 allonges 100 mm - 5 rallonges diffuseur 35 mm buses gaz : 4 courtes + 4 longues guides fil : 5 courts + 5 longs</p>		 <p>1 douille de réduction traction torche 1 douille de réduction blocage torche</p>

01-17-11